

OLYMPUS 1000W 150mm

OLYMPUS

FRESNEL OLYMPUS 100W 150MM

Location and Studio Fresnels offer style, durability, performance and efficiency. Ideal general purpose keylight and backlight for television studios and motion picture.

- ◆ Front and back focusing. Worm drive mechanism for focusing.
- ◆ Thermal shock resistant borosilicate fresnel lenses made in Germany.
- ◆ New easy running barndoor ears
- ◆ Superior optical performance with specially designed reflectors.
- ◆ Tubular steel yokes.
- ◆ Safety screen
- ◆ Easy to service and maintain
- ◆ These equipments comply with all applicable European directives and carry a CE mark.

Supplied with:

- 150mm Fresnel lens
- 8-leaf rotating barndoor
- Color frame
- G22 lampholder
- Safety grid
- In-line switch (additional)
- 2 m. Power supply cable

POLE OPERATION 50-03 PO

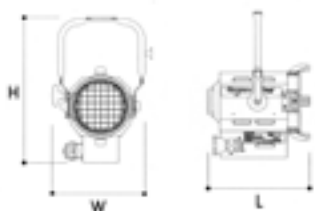
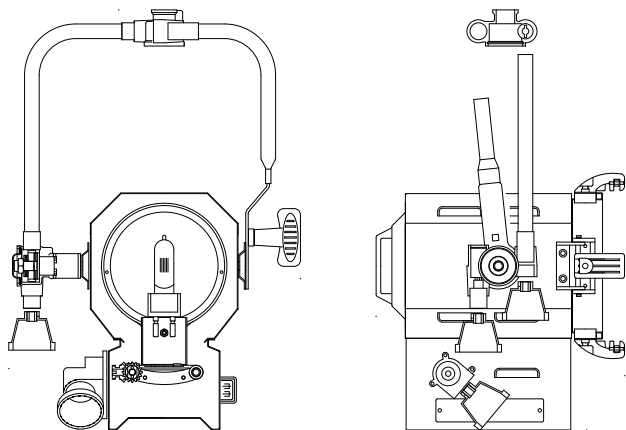

FRESNEL OLYMPUS 1000W 50-03

L	W	H	⚠	📦
323 (12.72")	293 (11.54")	448 (17.65")	8 (17.64 lbs.)	500x350x350 (19.69"x13.78"x13.78")

L Length. W Width. H Height (mm) ⚠ Weight (Kg) 📦 Package dimensions (mm)

MODEL 50-03



Photometric Data

With lamp CP 40/FKJ 1000W-220V

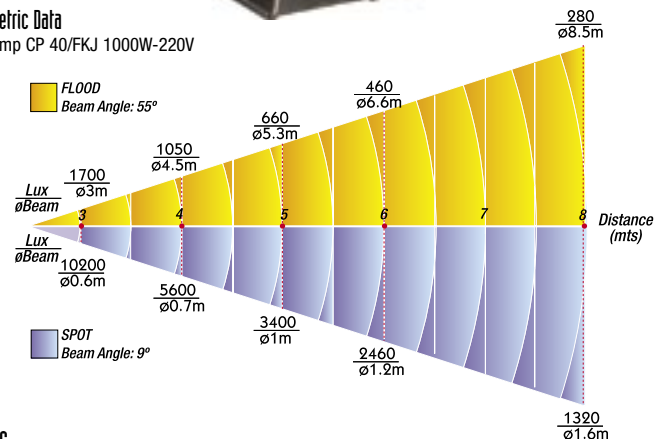

LAMPS

ANSI COD.	LIF COD.	BRAND CODE	W	V	SOCKET	LIFE HS	°K
FKJ	CP40	64747 OSRAM	1000	220	G22	200	3200
FKJ	CP40	CP40	1000	220	G22	200	3200
EGT	CP40	EGT GE	1000	120	G22	250	3200
FKH	CP39	CP39	650	220	G22	150	3200
EGN		EGN GE	500	120	G22	150	3200

Fresnel OLYMPUS 1000W

ACCESSORIES

